

## VARIOMOD modules and interface module XC Communication and interface modules for LZQJ-SGM, LZQJ-XC and DMTZ-XC

### EN Instructions for use

Scope of delivery and storage/transport.....	2
Important information.....	2
Target audience.....	2
Intended use.....	2
Maintenance and warranty instructions.....	3
Care and disposal instructions.....	3
Basic safety instructions.....	3
General description.....	4
Technical data.....	4
Housing and display elements.....	5
VARIOMOD LED functions.....	5
Installation and start-up.....	7
Antenna assembly (LTE versions).....	7
Network connection for the VARIOMOD XC <sup>ethernet</sup> .....	8
Inserting/removing the SIM card (LTE versions).....	8
Inserting module into meter.....	9
Removing the module.....	9
VARIOMOD connections.....	11
Interface module XC connections.....	11
VARIOMOD/interface module XC voltage supply.....	13
Connecting devices to VARIOMOD.....	14
Connecting devices to interface module XC.....	15
EU Declarations of Conformity.....	16

Issue date: 28 February 2025; subject to technical changes.

VARIOMODULES-BIA-E-4.05

Degree of protection	Housing: IP 20
Weight	approx. 60 g LTE versions: approx. 90 g (XC <sup>lte</sup> ) approx. 90 g (LTE M)

### Housing and display elements

The following figure shows the housing and display elements:

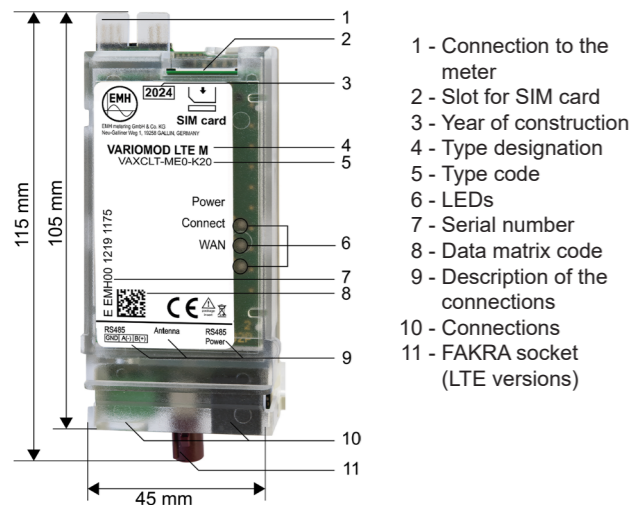

- 1 - Connection to the meter
- 2 - Slot for SIM card
- 3 - Year of construction
- 4 - Type designation
- 5 - Type code
- 6 - LEDs
- 7 - Serial number
- 8 - Data matrix code
- 9 - Description of the connections
- 10 - Connections
- 11 - FAKRA socket (LTE versions)

### VARIOMOD LED functions

Once power has been applied (power LED lit/flashing) or after a restart, the VARIOMOD performs an initialisation.

If the error LED is lit or flashing in the XC<sup>ethernet</sup> version, a fault has occurred.

**i** On the LTE versions of the VARIOMOD, all three LEDs flash simultaneously when a fault has occurred.

### Scope of delivery and storage/transport

Please check that the contents of the packing box are complete before starting with the installation and start-up procedure.

- 1 communication module or 1 interface module
- 1 instructions for use

Accessories (optional):

- Adapters for spring-loaded terminals
- LTE: Antenna with FAKRA plug

If the contents are incomplete or damaged, please contact your supplier.

Store, use and transport the device in such a way that it is protected against moisture, dirt and damage and so that the contact pins are not damaged.

### Important information

#### Target audience

These instructions are intended for technicians who are responsible for the installation, connection and servicing of the devices. The devices must be installed and put into operation only by qualified electricians in accordance with generally accepted rules of technology and the regulations that are relevant for the installation of telecommunications equipment and end devices.

#### Intended use

The devices in the VARIOMOD series are designed exclusively for the transfer of measurement data in combination with approved measuring devices as per the technical description, and only after correct installation.

The interface module XC may only be used as an interface extension, only in combination with devices in series LZQJ-XC, LZQJ-SGM and DMTZ-XC as per the technical description, and only after correct installation.

### Maintenance and warranty instructions

The devices are maintenance-free. It is not permitted to make any repairs independently in the event of any damage (e.g. due to transport or storage).

If the device is opened, the warranty and the Declaration of Conformity will be rendered null and void. The same applies where a defect is caused by external factors (e.g. lightning, water, fire, extreme temperatures and weather conditions), or by improper or careless use or handling.

### Care and disposal instructions

Use a dry cloth to clean the device housing. Do not use any chemical cleaning agents!



The symbol showing a crossed-out waste bin on electrical and electronic devices indicates that the device in question must be disposed of separately from unsorted domestic waste after decommissioning. You will find further disposal instructions on the manufacturer's website.

### Basic safety instructions

Please adhere to the following basic safety instructions:

- Before assembly, check the devices for any externally visible damage.
- Observe the applicable occupational health and safety regulations for electrical installations.



Only the original EMH antennas listed here are approved for operation in accordance with EU Radio Equipment Directive 2014/53/EU (RED).

In the event of a fault, please contact your supplier.

LED	VARIOMOD LTE M / VARIOMOD XC <sup>lte</sup>	VARIOMOD XC <sup>ethernet</sup>
<b>Power</b> (green)	<b>Flashing:</b> Connection with meter established, SIM card initialised, display of field strength (field strength is determined from switch-on time or number of flashes) <b>Lit:</b> Voltage supply connected, but no connection to meter, or SIM card not initialised, or login to LTE network not possible <b>Off:</b> No voltage supply	<b>Flashing:</b> Connection with meter and network established <b>Lit:</b> Voltage supply connected, but no connection to meter or network <b>Off:</b> No voltage supply
<b>Connect</b> (yellow/green)	<b>Off:</b> No IP address <b>Flashing:</b> Connecting (IP address of the APN, in IP-T server login if applicable) <b>Lit:</b> Connection established (IP address assigned, IP-T login if applicable)	<b>Flashing:</b> Connecting <b>Flashes quickly:</b> IP-T login in progress <b>Lit:</b> Connection established, IP-T login completed (in IP-T mode)
<b>Error</b> (red)		<b>Flashing:</b> Error <b>Lit:</b> Error
<b>WAN</b> (green)	<b>Flashing:</b> 2x to display the 2G network. 4x to display the 4G network.	-

### Installation and start-up

#### Antenna assembly (LTE versions)



**DANGER**

#### Risk of fatal injury due to voltage flashover!

Route the supply line (antenna, Ethernet etc.) in such a way that a minimum distance of 10 mm from all connecting lines and terminals of the meter is ensured.

The 2G magnetic base antennas [1], the 2G/4G multiband antennas [2] and the connecting adapters [3] are connected to the FAKRA socket of the module.

To ensure optimum antenna reception, the antenna should be assembled outside the switch cabinets. The magnetic base antenna should be placed on a horizontal magnetic surface.



#### ATTENTION

#### Damage to the antenna connection due to incorrect combination!

The connecting adapter [3] must not be combined with the terminal cover for modem installation.



**WARNING**

#### The radio transmitter of the VARIOMOD LTE M and the VARIOMOD XC<sup>lte</sup> can impair the function of electronic devices (e.g. pacemakers)!

- Comply with the information signs and do not operate the device in areas where mobile phones are prohibited.
- The antenna of the device must be installed and operated at a minimum distance of 30 cm from people.
- Contact the responsible doctor or the device manufacturer if necessary.

### General description

The VARIOMOD is a communication module with modem functionality for remote retrieval from meters in the LZQJ-SGM, LZQJ-XC and DMTZ-XC series. Furthermore, it is equipped with an RS485 interface that can be looped through for remote retrieval from additional connected electricity, gas or water meters.

The following versions are available:  
 VARIOMOD LTE M, VARIOMOD XC<sup>lte</sup> and VARIOMOD XC<sup>ethernet</sup>.

The interface module XC is equipped with an RS232 interface and an RS485 interface.

### Technical data

Voltage supply	via meter or external wall power supply
Band	LTE M: 700(B28) / 800(B20) / 900(B8) / 1800(B3) / 2100(B1) MHz XC <sup>lte</sup> : 800(B20) / 900(B8) / 1800(B3) MHz
Transmission power	max. 2 W to 900 MHz max. 1 W from 1800 MHz
Temperature range	Operation: -25 °C...+55 °C Storage: -40 °C...+80 °C
Humidity	max. 95%, non-condensing
Dimensions (housing)	45 x 105/115 x 27 (W x H x D) mm

### Network connection for the VARIOMOD XC<sup>ethernet</sup>

To connect the module to a network, plug an Ethernet cable into the left socket [1]. The plug must engage in the process. Plug the other end of the Ethernet cable into a network socket [2], a switch [3] or a network jack of a computer.

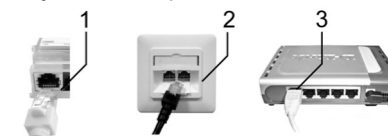

### Inserting/removing the SIM card (LTE versions)

#### ATTENTION

#### Damage to the SIM card due to short circuit!

Always insert the SIM card when the module is de-energised.

Before the module is installed in the meter, it is necessary to insert a SIM card that is activated for data traffic. SIM cards with the PIN deactivated, or with the PIN "0000" may be used. If you want to use a SIM card with a different PIN, you have to reconfigure the module with the VARIOMOD Manager.

#### Inserting the SIM card

Push the SIM card [1] into the card slot until it engages.

#### Removing the SIM card

Press the SIM card down slightly [2]. The card is then pushed up automatically [3]. Now remove the card [4].

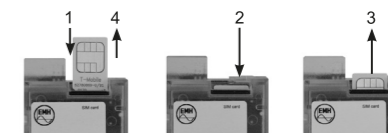

## Inserting the module into the meter



### Risk of fatal injury in case of contact with live parts!

The module can be inserted under voltage.

Make sure that unintentional contact with the connection terminals of the meter is impossible.

1. LTE modem only: Insert the SIM card.
2. Connect the connecting/antenna cables to the module.
3. Remove the terminal cover of the meter [5].
4. Open the module compartment flap [1].
5. Insert the module [3] in the module compartment [2].
6. Push the module into the module slot until it engages noticeably.
7. Close the module compartment flap of the meter [1].
8. Install the terminal cover [5] on the terminal block [4].

## Removing the module



### Risk of fatal injury in case of contact with live parts!

The module can be removed under voltage.

Make sure that unintentional contact with the connection terminals of the meter is impossible.

1. Remove the terminal cover of the meter [5].
2. Open the module compartment flap [1].
3. Push the module out of the module compartment [2].
4. Close the module compartment flap [1].
5. Install the terminal cover [5] on the terminal block [4].
6. Unplug the connecting/antenna cables on the module.

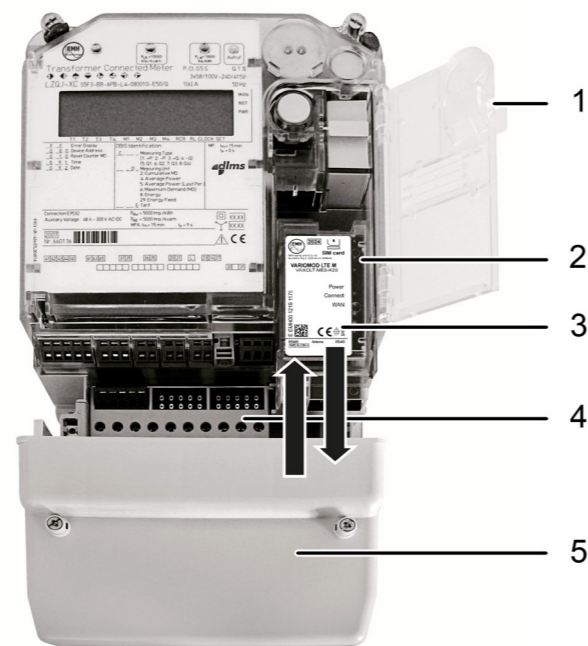

Legend:

- 1 - Module compartment flap
- 2 - Module compartment
- 3 - Module
- 4 - Terminal block
- 5 - Terminal cover

9

10

## VARIOMOD connections

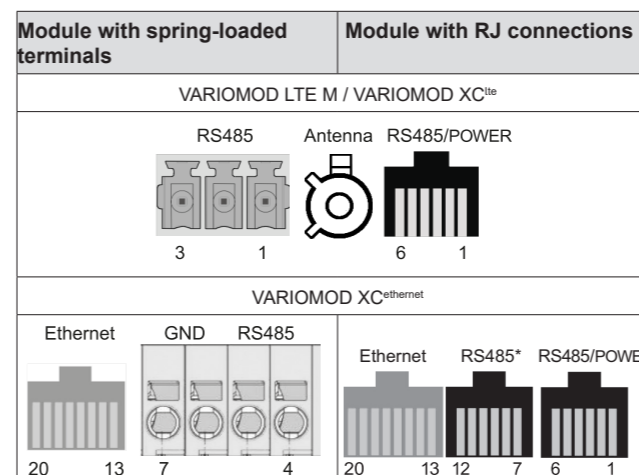

## Interface module XC connections

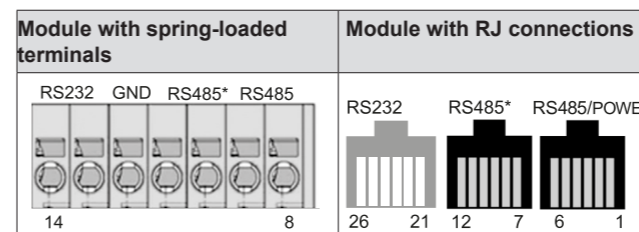

The table below summarizes the pin assignment of the individual interfaces.

\*Loop-through operation RS485

11

## Pin assignment for VARIOMOD and interface modules

Pin no. RJ connections	Pin no. Spring-loaded terminals	Designation	Function
1	-	GND	Device earth
2	-	RS485 A (-)	"Negative" connection of the RS485 interface
3	-	RS485 B (+)	"Positive" connection of the RS485 interface
4	-	N.C.	Not assigned
5	-	GND	Device earth
6	-	+UB	External supply 12-18 V DC (optional)
7*	3*, 6, 7	GND	Device earth
8*	2*, 5, 9, 11*	RS485 A (-)	"Negative" connection of the RS485 interface
9*	1*, 4, 8, 10*	RS485 B (+)	"Positive" connection of the RS485 interface
10	-	N.C.	Not assigned
11	-	N.C.	Not assigned
12	-	N.C.	Not assigned
13	-	TX+	Transmission line
14	-	TX-	Transmission line
15	-	RX+	Receiving line
16	-	N.C.	Not assigned
17	-	N.C.	Not assigned
18	-	RX-	Receiving line
19	-	N.C.	Not assigned
20	-	N.C.	Not assigned
21	12	GND	Device earth
22	14	RS232 TxD	Transmission line
23	13	RS232 RxD	Receiving line
24	-	N.C.	Not assigned
25	-	N.C.	Not assigned
26	-	N.C.	Not assigned

12

## Spring-loaded terminals conductor cross-section

	Cable	Min.	Max.
VARIOMOD LTE M / VARIOMOD XC <sup>lte</sup>	rigid	0.2 mm <sup>2</sup>	1.5 mm <sup>2</sup>
	flexible with ferrules and plastic collar (stripping length 10 mm)	0.25 mm <sup>2</sup>	0.75 mm <sup>2</sup>
VARIOMOD XC <sup>ethernet</sup>	rigid	0.2 mm <sup>2</sup>	4 mm <sup>2</sup>
	flexible with ferrules and plastic collar (stripping length min. 8 mm)	0.25 mm <sup>2</sup>	1.5 mm <sup>2</sup>
Interface module XC	rigid	0.2 mm <sup>2</sup>	4 mm <sup>2</sup>
	flexible with ferrules and plastic collar (stripping length 8 mm)	0.25 mm <sup>2</sup>	1.5 mm <sup>2</sup>

## VARIOMOD/interface module XC voltage supply

The communication module or interface module is supplied with operating voltage via the meter if the meter is equipped with the necessary mains adapter.

Please see the configuration of the meter to determine whether this mains adapter is available. If no corresponding mains adapter is available, please contact your supplier.

Alternatively, power the communication module with an RJ socket by means of an external DC source; see figure.

Operating voltage: 12-18 V DC  
Current consumption: max. 0.5 A

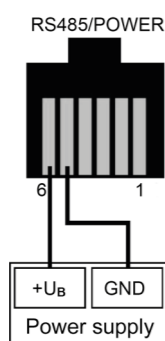

## Connecting devices to VARIOMOD

Connect the module to external devices as shown in the circuit diagrams below.

### Module with RJ connections

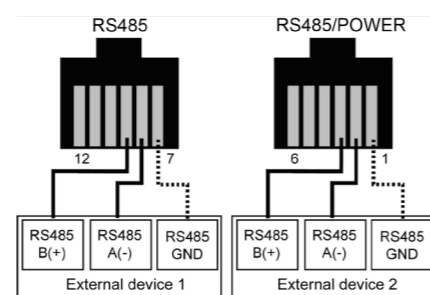

●●● Potential equalisation

### Module with spring-loaded terminals

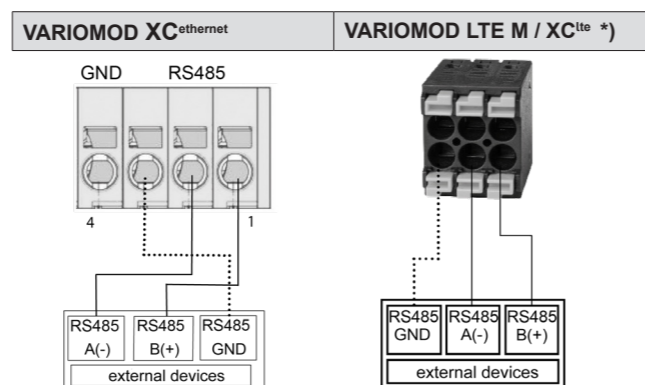

●●● Potential equalisation

●●● Potential equalisation

\* Accessories: Socket for 1.5 mm<sup>2</sup>

14

## Connecting devices to interface module XC

The interface module is equipped with an RS232 and an RS485 interface that can be looped through; however, only one interface variant can be used. Parallel operation is not possible!

Connect the interface module XC to external devices as shown in the circuit diagrams below.

### Module with RJ connections

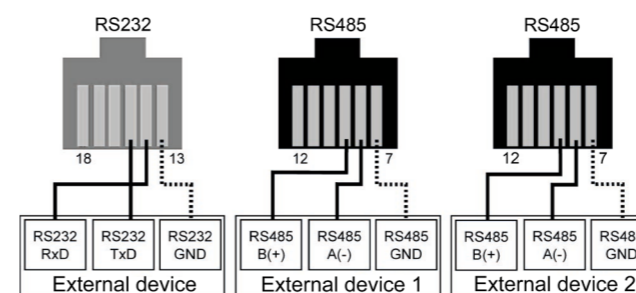

●●● Potential equalisation

### Module with spring-loaded terminals

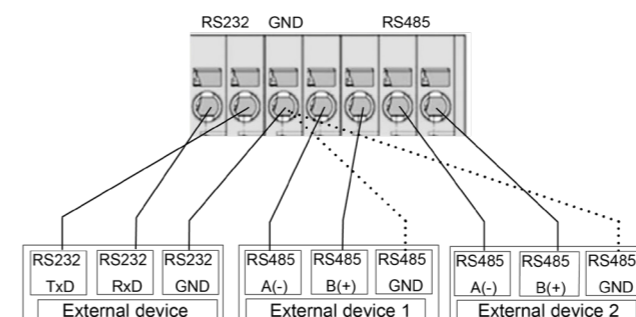

●●● Potential equalisation

15

## EU Declarations of Conformity

EMH metering hereby declares that the VARIOMOD LTE M and the VARIOMOD XC<sup>lte</sup> comply with the following Directive:

- Radio Equipment Directive (RED) 2014/53/EU

EMH metering hereby declares that the VARIOMOD XC<sup>ethernet</sup> and the interface module XC comply with the following Directive:

- Electromagnetic Compatibility (EMC) 2014/30/EU

**i** You will find the current EU Declaration of Conformity on the internet site [www.emh-metering.com](http://www.emh-metering.com) in the "Products & Solutions" area in the product description for the device. As Declarations of Conformity may differ in terms of the applicable standards, we advise you to save the Declaration of Conformity available at the time of delivery.

13

